

**READ THESE INSTRUCTIONS COMPLETELY BEFORE STARTING WORK.  
IF YOU DON'T UNDERSTAND CALL 724-588-8600 FOR ASSISTANCE.**

# PROCEDURE FOR REPLACING LOWER SHACKLE ASSEMBLY

**THIS KIT IS TO BE USED ONLY ON WERNER CO.  
PUMP JACKS**



**WARNING:**

1. Failure to comply with all instructions may result in serious injury.
2. Make sure this kit fits your pump jack. Refer to the application chart on the outside of the kit's packaging. If you have any questions concerning the use of this kit on other Werner Co. products, call 724-588-8600 for assistance.
3. Before installing this kit, identify all kit components. If any components are missing or damaged, return the kit to place of purchase. Do not substitute any components.
4. Inspect the pump jack before installing this kit. Repair or replace any damaged or missing parts before using the pump jack. Use only Werner Co. repair or replacement parts. If unable to repair, discard the pump jack.

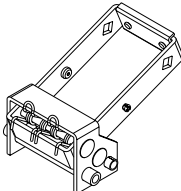
COMPONENTS IN KIT	TOOLS REQUIRED
(1) Lower Shackle Assembly 	(2) 9/16 Wrench

## INSTRUCTIONS:

### Removing Lower Shackle Assembly:

- STEP 1.** Loosen thumb screws and extend pump jack platform support to expose bolt and nut as shown in Figure 1.
- STEP 2.** Remove cotter pins from lower foot lever and slide lower foot lever out of lower shackle assembly as shown in Figure 1. Do not discard cotter pins, they will be used to reattach lower lever.
- STEP 3.** Using wrenches, remove two bolts, lock washers and nuts from lower shackle assembly and pump jack assembly rails as shown in Figure 1. Do not discard fasteners, they will be used to reattach lower shackle assembly.
- STEP 4.** Remove lower shackle assembly from bottom of pump jack assembly as shown in Figure 2.

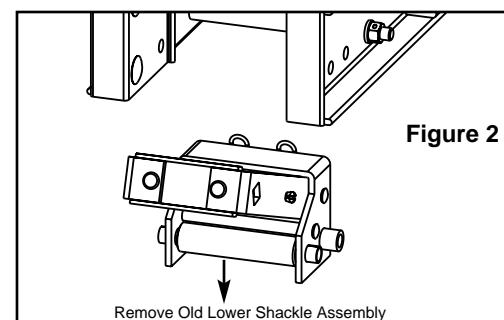
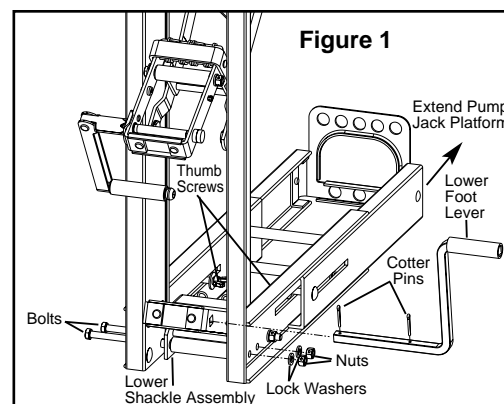

## INSTRUCTIONS:

### Installing Lower Shackle Assembly:

- STEP 1.** Install lower shackle assembly through bottom of pump jack assembly so that holes in shackle assembly line up with holes in pump jack rail assembly as shown in Figure 3.
- STEP 2.** Insert two bolts through lower shackle assembly and pump jack assembly rails as shown in Figure 4 and attach each with a lock washer and nut.
- STEP 3.** Tighten both nuts in order to hold assembly firm to pump jack assembly rails.
- STEP 4.** Install lower foot lever into lower shackle assembly and attach using cotter pins as shown in Figure 4.

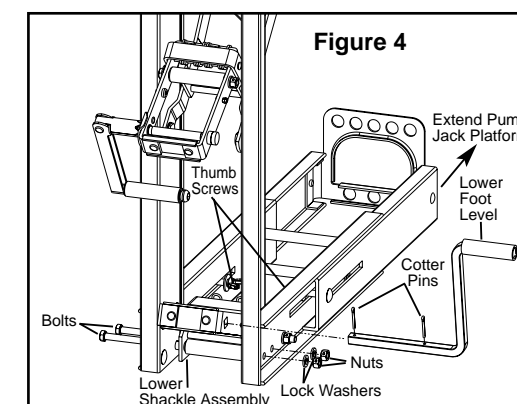
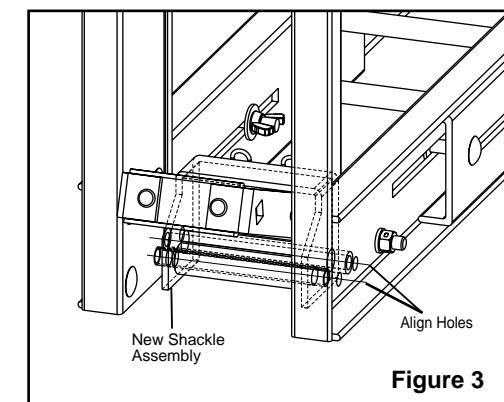

**CAUTION: IF ANY PARTS ARE DAMAGED OR MISSING, CONTACT PLACE OF PURCHASE FOR REPLACEMENT KITS, IF AVAILABLE, OR DISCARD UNIT.**



WERNER CO., 93 WERNER ROAD, GREENVILLE, PA 16125-9499  
PHONE (724) 588-8600 www.wernerladder.com