

TRIMMING AND ADJUSTING THE ACCESS LADDER LEGS

STEP 6. Place a support under the lower section of the access ladder. Using a hack saw with metal cutting blade, cut both access ladder legs off along the line drawn that corresponds to the "F" measurement. **DO NOT TRIM THE LEGS TOO SHORT!** If the access ladder is used when the legs are too short, it will be damaged and could break unexpectedly resulting in serious injury.

STEP 7. Fully extend the access ladder and place the adjustable feet on the rails. Adjust the feet so that there are no gaps between the metal hinges and the feet are flush with the floor (Figure 26). Using the hole in the adjustable feet as a guide, drill through the rails using a 13/64" diameter bit (Figure 27). Using the nuts, washers and bolts provided, bolt the adjustable feet to the rails (Figure 28).

WARNING: Gaps between the metal hinges mean that the feet are not properly adjusted (Figures 29 and 30). Do not climb the access ladder if there are gaps between the hinges — it will be damaged and could break unexpectedly resulting in serious injury.

If the access ladder looks like Figure 29, then one or both of the feet are too long. If the access ladder looks like Figure 30, then one or both of the feet are too short. If there are no gaps between the hinges but one of the feet does not touch the floor, then the access ladder is not safe to use. Do not use the access ladder — CALL: Werner Ladder Co. 1-724-588-8600

STEP 8. Remove the temporary support boards with a pry bar or claw hammer.

CONGRATULATIONS!
Your Installation is complete!

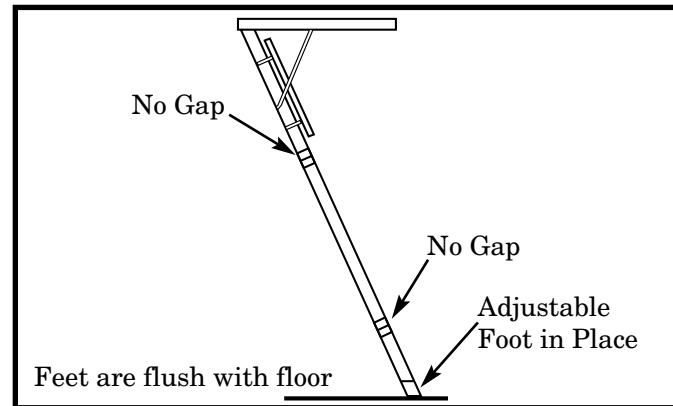

Figure 26 Connect Setup

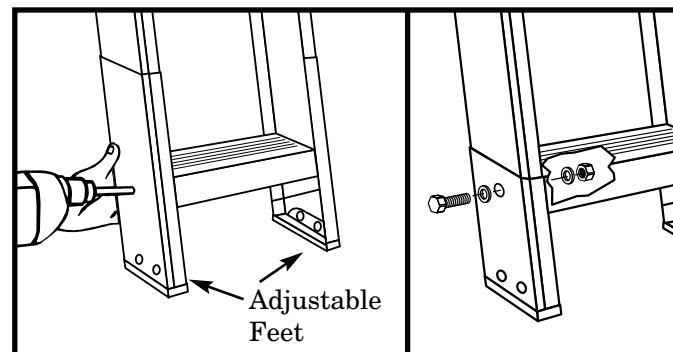

Figure 27

Figure 28

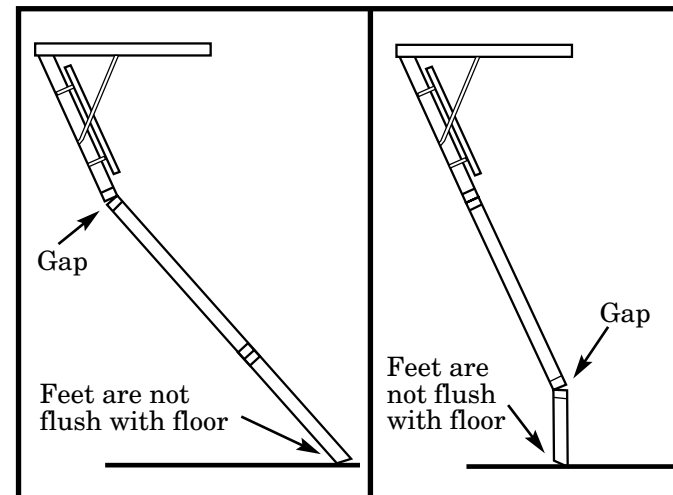

Figure 29 Legs too long

Figure 30 Legs too short



WERNER LADDER CO., 93 WERNER ROAD, GREENVILLE, PA 16125-9499
Phone: (724) 588-8600

www.wernerladder.com



SpaceMaster®

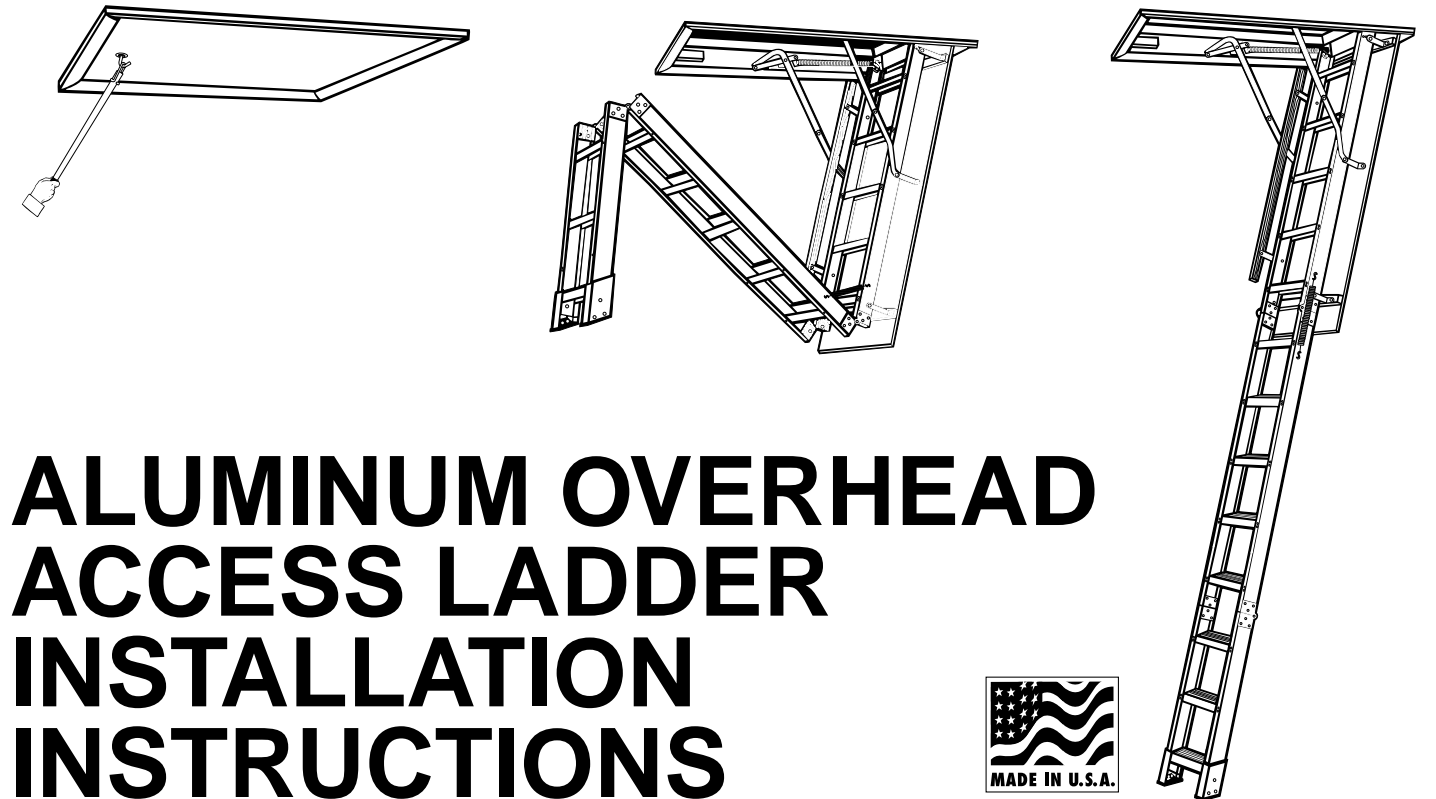

ALUMINUM OVERHEAD ACCESS LADDER INSTALLATION INSTRUCTIONS



FAILURE TO COMPLY WITH ALL INSTRUCTIONS MAY RESULT IN SERIOUS INJURY

Table of Contents

	Page
Section 1 Important Questions to Answer	1
– Are you capable of installing this access ladder?	1
– Does this Access ladder meet your needs?	1
– Is your ceiling and joist structure suitable?	1
– Do these instructions meet your needs?	1
Section 2 Checking the Access Ladder Condition	2
Section 3 Persons, Tools and Materials Needed	3
Section 4 Prepare Access Ladder for Installation	3
Section 5 Finding a Suitable Location	4
Section 6 Cutting a Hole in the Ceiling	6
Section 7 Cutting the Ceiling Joists	7
Section 8 Framing the Rough Opening	8
– Installing Headers	8
– Installing Stringers	11
Section 9 Installing Temporary Support Boards	11
Section 10 Positioning the Access Ladder	12
Section 11 Shimming, Squaring and Nailing the Access Ladder in Place	13
Section 12 Trimming and Adjusting the Access Ladder Legs	14

Section 1

IMPORTANT QUESTIONS TO ANSWER

Read instructions completely before beginning.

This is necessary to ensure that you have a suitable location for the access ladder and the ability to safely and properly install it.

Are you capable of installing this access ladder?

To install this access ladder you should have sawing, squaring, and aligning skills similar to those required to install a window or a door frame. If you do not have these skills you should hire a professional carpenter to install this unit (see the Yellow Pages under “Building Contractors, Carpenters, Home Builders, Home Improvements, or Contractors-General”).

Does this access ladder meet your needs?

This access ladder is for residential use only. Installing this access ladder in commercial buildings and apartments may violate building codes that require fire-rated ceilings and prohibit storing materials in the overhead space! Check with your local fire marshal or building department before installing the access ladder.

The capacity of the access ladder (person plus materials being carried) is 300 pounds for Models A2208, A2210, A2508, A2510 and A2512.

This access ladder is made for the range of ceiling heights shown on the box. Do not install the access ladder in a ceiling that has a height outside of this range. Altering the access ladder to accommodate other heights is unsafe.

Is your ceiling and joist structure suitable for this installation?

This access ladder can be installed in structures with conventional wood roof frames (see Figure 1). If a ceiling is present, you must have an access hole in the ceiling that allows you to enter the overhead space for a pre-installation inspection.

Roof support structures that have braces connected to the ceiling joists or which use trusses (see Figure 2) cannot be cut without destroying the load-bearing capacity of that section of the roof. Do not cut joists that are part of a braced conventional frame or truss without first consulting an architect or structural engineer (see the Yellow Pages under “Architects or Structural Engineers”).

The access ladder should **not** be installed in a ceiling that has any of the following:

- components of heating/cooling systems embedded in the ceiling
- joists made of materials other than wood
- metal reinforced plaster
- suspended ceilings

If your ceiling contains any of the above, do not attempt to install the access ladder. Contact a professional for assistance with your specific needs (see the Yellow Pages under “Heating and Cooling Contractors, Building Contractors, Carpenters, Home Builders, Home Improvements, or Contractors-General”).

Do these instructions meet your needs?

These instructions describe how to install the access ladder parallel or perpendicular to the ceiling joists. Contact a professional if you want the access ladder installed in some other direction relative to the joists.

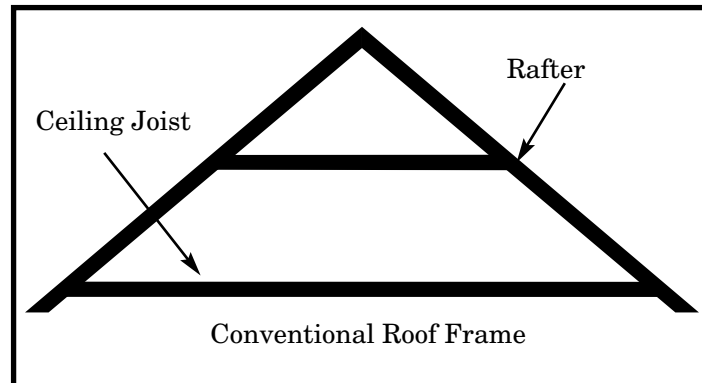

Figure 1 Conventional roof frame.

Section 1 (Continued)

IMPORTANT QUESTIONS TO ANSWER

Is your ceiling and joist structure suitable for this installation?

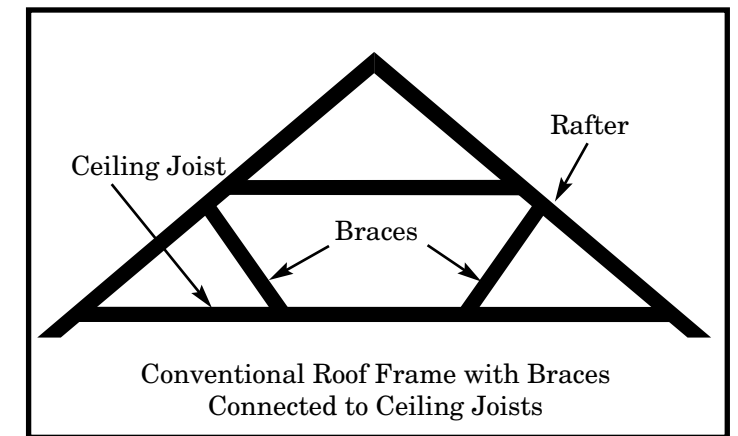
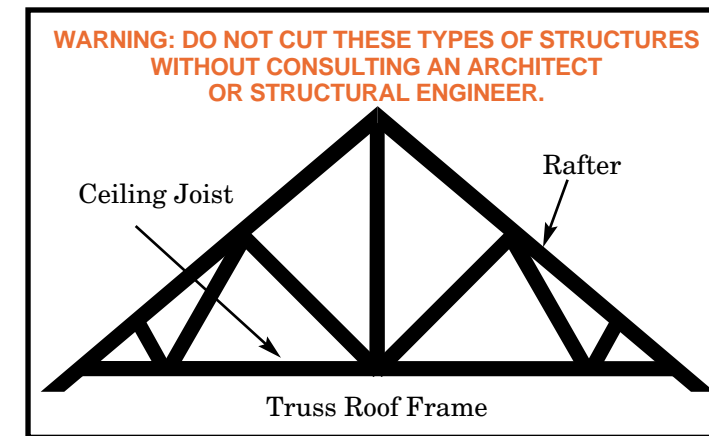

Figure 2 Truss roof frame and conventional roof frame with braces connected to ceiling joists.

Section 2

CHECKING THE ACCESS LADDER CONDITION

You should have the following items in the access ladder box:

(12' MODEL ONLY)

- | | |
|--|--|
| <ul style="list-style-type: none"> - (1) Access Ladder - (1) Door/Frame Assembly - (1) Push/Pull Down Rod and Hook Assembly - (1) Pair of Adjustable Access Ladder Feet - (2) Mechanism Springs - (2) 3/16" x 1/2" Hex Bolts - (2) Washers - (2) 3/16" Lock Nuts - (6) 1/4" x 1/2" Hex Bolts - (6) 1/4" Lock Nuts - (2) 5/16" x 7/8" Hex Bolts - (2) 5/16" Lock Nuts | <ul style="list-style-type: none"> - (1) Pair of Spring Assist Assemblies - (1) Pair of Rubber Bumpers - (1) Step Hook Assembly - (1) Spring Latch - (1) 1/4" x 1/2" Hex Bolt - (1) 1/4" Lock Nut - (2) 3/16" x 5/8" Slot Head Screws - (2) 3/16" Lock Nuts - Easy To Understand Instructions |
|--|--|

To save time and prevent accidents, inspect the access ladder for shipping damage before beginning the installation.

- Check the wooden frame and door panel for splits in the wood.
- Check all metal parts for damage such as bends and cracks.
- Check that all rivets are tight.

If any items are missing or damaged, contact the place of purchase or Werner Ladder Co. at 1-724-588-8600.

Section 3

PERSONS, TOOLS AND MATERIALS NEEDED

People Required

- 2 people (one of whom is capable of lifting the 70 pound access ladder into the overhead space)

Materials

- several pieces of joist-sized lumber (the amount depends on the specific installation)
- 2 boards, 1" x 4" x 36", to serve as temporary support boards
- boards to lay across joists to make a working platform in the overhead space
- wood shim stock
- 16d sinker nails (24-60 depending on the specific installation)
- 20d sinker nails are needed for installations where joists are cut

Stepladder

- You need a stepladder that is tall enough so that you can get into the overhead space without stepping above the working height of the stepladder. The working height of the stepladder is two steps down from the top.
- Your stepladder must also have a Duty Rating that is greater than the sum of your weight plus the 70 pound weight of the access ladder.

CAUTION: Be careful when using a stepladder to climb into and out of the overhead space. Have the second person hold the stepladder so that it does not tip over.

Tools

- flashlight or extension light to provide light in the overhead space
- claw hammer
- pencil
- handsaw
- handsaw with metal cutting blade
- tape measure
- framing square
- tools to cut a hole in the existing ceiling
- drill
- 1/8" drill bit
- 13/64" diameter drill bit
- tools to tighten nuts and bolts

Safety Equipment

- gloves
- safety goggles
- dust mask

Section 4

PREPARE ACCESS LADDER FOR INSTALLATION

STEP 1. Using the (6) 1/4" nuts and bolts, provided in the bag with the adjustable feet, attach the ladder to the frame by bolting through the angle brackets and then the ladder side rail (see Figure 3).

The angle brackets located at the top and bottom of the frame will use the holes in the center of the bracket. The angle brackets located at the middle of the frame will use the top holes in the bracket.

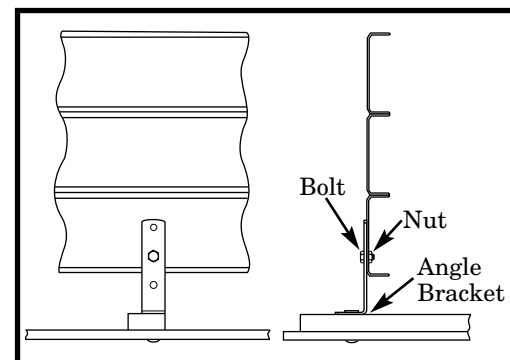

Figure 3

Section 4 (Continued)

PREPARE ACCESS LADDER FOR INSTALLATION

STEP 2. After the ladder is attached to the 6 brackets on the frame the mechanism arm should then be attached to the middle angle brackets by using the (2) 5/16" nuts and bolts to bolt through the mechanism arm and the bottom hole in the angle bracket (see Figure 4).

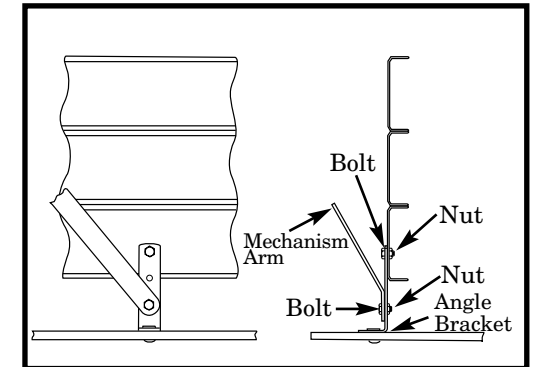

Figure 4

STEP 3. Attach one end of a spring to a mechanism arm and the opposite end of spring up through clip in metal corner bracket of frame (see Figure 5).

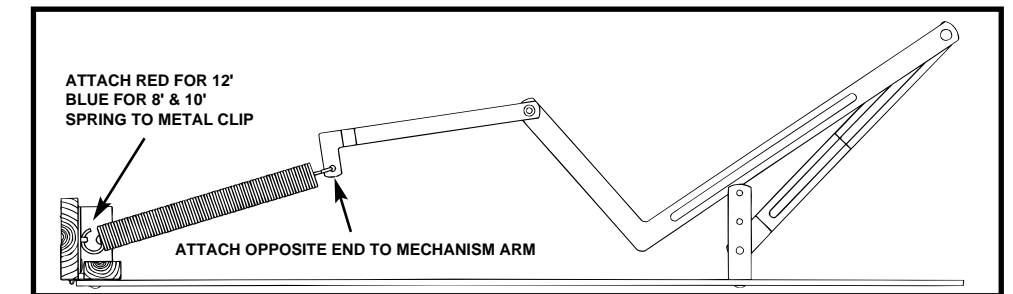

Figure 5

Section 5

FINDING A SUITABLE LOCATION

Before Proceeding: You must have: a) a suitable ceiling and joist structure, b) the persons, tools and materials needed, c) the appropriate ladder for your ceiling height (see Figure 6 and Table 1 below), and d) a level and flat location in the ceiling.

Goal: To find a location free of hazards and obstructions that will provide room for the installation and use of the access ladder.

STEP 1. Pick a potential location for installation.

If you are installing the access ladder in a garage, don't forget to consider where cars will be parked.

STEP 2. Check that you have the swing clearance (SC) needed (see Figure 6 and Table 1).

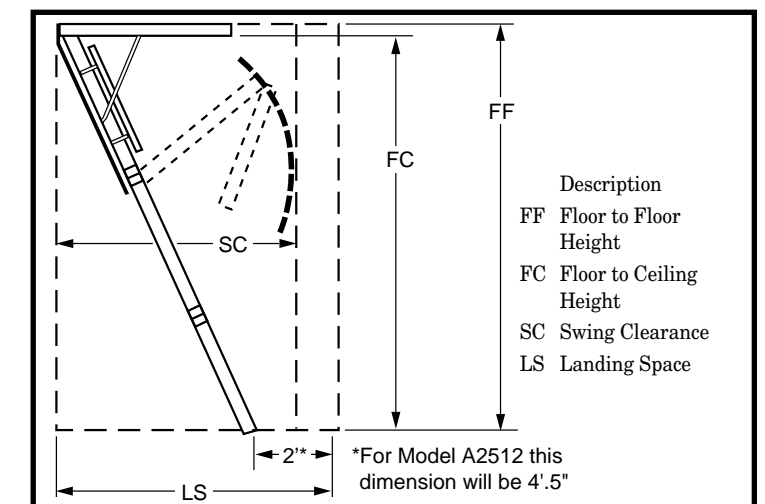

Figure 6

FINDING A SUITABLE LOCATION

STEP 3. Check that you have the landing space (LS) needed to let both legs rest flat on the floor (see Figure 6 and Table 1).

STEP 4. If there is no ceiling and the access ladder will fit between the joists so that no joists need to be cut, go to Section 8 “FRAMING THE ROUGH OPENING” on page 12.

If there is no ceiling, but one or more joists need to be cut, go to Section 7 “CUTTING THE CEILING JOISTS” on page 10.

If there is a ceiling at this location, you will need to inspect the overhead space above this location as described in Steps 5 and 6.

Table 1

Access Ladder Model Number	SC	LS	FF	FC
A2208 A2508	5' 2"	6' 5"	7' 3" min. to 8' 9" max.	7' min. to 8' 5" max.
A2210 A2510	6' 2"	7' 3"	8' 9" min. to 10' 3" max.	8' 5" min. to 10' max.
A2512	7' 10"	12' 6"	10' 7" min. to 12' 4" max.	10' 3" min. to 12' max.

WARNING: For your safety, watch out for overhead hazards. Do not stand or sit on the ceiling or insulation covering the ceiling — the ceiling is not made to support your weight. You can fall through the ceiling even though it looks solid! Only the joists can support weight. Watch out for sharp nails sticking through the roof.

STEP 5. Go into the overhead space and find the area above your chosen location. This area may be located by:

- 1) listening for tapping from below, or
- 2) measuring distances from walls or other objects common to the overhead space and the room below.

WARNING: Do not drive metal nails or other conductive objects into the ceiling unless you are sure they will not contact electric wires. Contact with an electric wire can be deadly.

STEP 6. At this location in the overhead space:

- a. Check that there is enough space for you to safely move around during installation.
- b. Check the overhead space for storage space adjacent to the chosen location. If walking or crawling in the overhead space is desired, make sure that there is enough room to do so.
- c. Check above your chosen location for hazards and obstructions such as:
 - electric wires
 - pipes
 - heating and cooling ducts
 - furnaces
 - hot water heaters or other obstructions

Note: To check for hazards, you will need to move insulation away from your chosen location. Wear a dust mask, safety goggles, and gloves and keep your body covered to prevent fine cuts from fiberglass. Gently push aside insulation to avoid stirring up dust that may be harmful to your eyes and lungs.

STEP 7. If any hazards or obstructions are present at your chosen location, look for another location or have the hazards or obstructions moved by professionals (see the Yellow Pages under “Electrical Contractors, Heating and Cooling Contractors, and Plumbing Contractors”).

CUTTING A HOLE IN THE CEILING

Before Proceeding: You must have a location that:

- a. is free of hazards and obstructions in the overhead space
- b. is free of hazards in the ceiling
- c. provides enough room for installation
- d. provides enough room to use the access ladder

Goal: To cut a hole, that is the correct size, in the ceiling at the desired location.

WARNING: Do not saw, cut, or hammer into the ceiling until you are sure that the location is free of hazards and obstructions in the ceiling and overhead space. Contact with an electric wire can be deadly.

STEP 1. Prepare the room by moving furniture, covering flooring with a drop cloth and removing children and pets to a safe distance away.

STEP 2. Put on safety goggles and a dust mask. These will keep pieces of ceiling particles and dust from falling into your eyes, mouth or nose as you make a starter hole and cut into the ceiling.

STEP 3. With a hammer and chisel, make a starter hole near the center of the chosen location. (See Figure 7)

STEP 4. Enlarge the opening with a saw until you can see a joist (See Figure 8).

STEP 5. Draw a rectangle the size of the rough opening on the ceiling, with one edge parallel to a joist (See Figure 9). You may do this by sawing until you reach a joist and using it as a frame of reference. (The size of the rough opening is shown on the box or in Table 2).

Note: Locating at least one edge of the opening along a ceiling joist will allow the joist to be used as a side of the frame you will build. This will simplify framing the rough opening.

STEP 6. Cut out the rest of the ceiling within the marked outline following these instructions:

- a. **Do not cut any joists at this time.** Cut through the ceiling only.
- b. Remove the ceiling in small pieces because ceiling material can be very heavy.

STEP 7. If no joists span the hole in the ceiling, go to Section 8 “FRAMING THE ROUGH OPENING” on page 12.

If any joists span the hole, go to Section 7 “CUTTING THE CEILING JOISTS” on the next page.

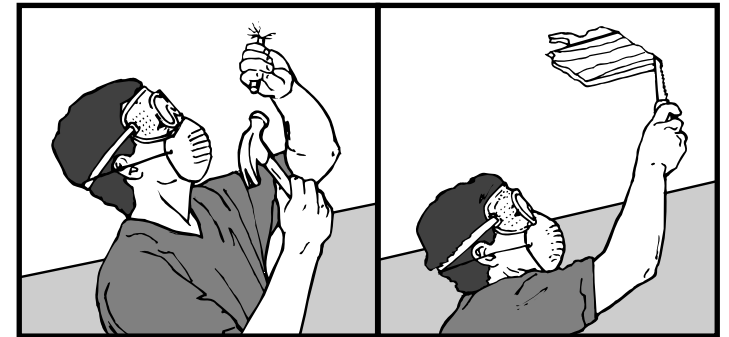

Figure 7 Make a starter hole near the center of the chosen location.

Figure 8 Enlarge the hole until you can see a joist.



Figure 9 Draw a rectangle the size of the rough opening.

Model Number	Rough Opening Size
A2208 A2210	22-1/2" × 54"
A2508 A2510	25" × 54"
A2512	25" × 66"

Table 2. Rough Opening Size

Section 7 CUTTING THE CEILING JOISTS

Before Proceeding: You must have either: a) exposed joists, or b) a correctly sized hole at the desired ceiling location.

Goal: To cut out any joists that are in the way of your chosen location. **Before cutting the joists, you must attach them to other joists in the overhead space to keep the ceiling from sagging or completely collapsing.**

STEP 1. If the room has a ceiling and you have cut the required hole, go to Step 2.

If the room has no ceiling, you will need to mark the joists according to (A) or (B) below.

- (A) If the chosen location is parallel to the joists, mark the rough opening length on top of the joists as shown in Figure 10. Do not cut the joist at this mark.
- (B) If the chosen location is perpendicular to the joists, mark the rough opening width on top of the joists as shown in Figure 11. **Do not cut the joist at this mark.**

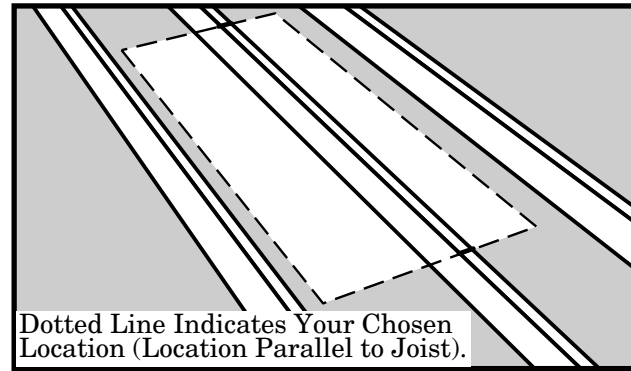

Figure 10

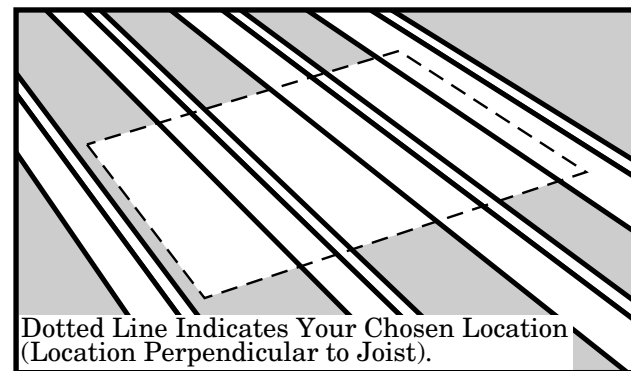

Figure 11

STEP 2. Cut 2 joist-sized boards long enough to span 2 joists on each side of your chosen location (Figure 12). These boards will support the joists that will be cut and help keep the ceiling from sagging or completely collapsing while you are working in the overhead space.

STEP 3. Place these boards approximately 24 inches from the edge of your chosen location and nail as shown in Figure 12.

Note: The 24 inch distance is needed to give you room to hammer nails into the frame that you will build in the next section.

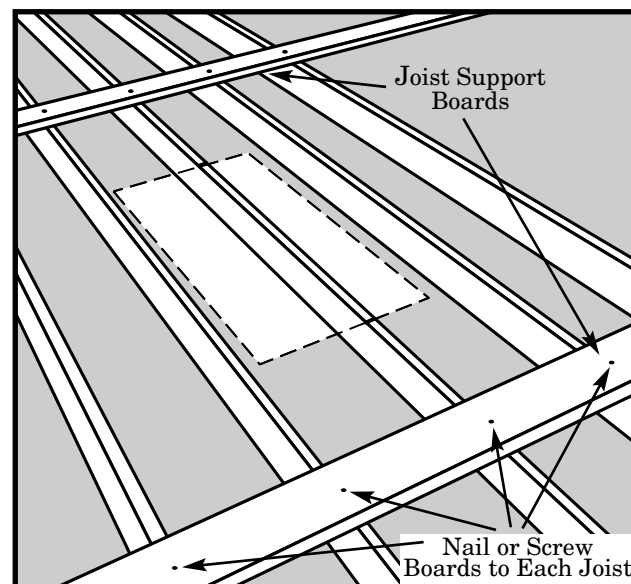

Figure 12

Section 7 (Continued) CUTTING THE CEILING JOISTS

STEP 4. Next, determine where the joist(s) should be cut. Figure 13 shows where to mark the joist(s) that span your chosen location. Note that the joist(s) should be marked back from the edge of your location a distance of 2 times the joist thickness (usually three inches). This leaves room for two joist-sized headers to be placed against each end of the cut joist(s) (see Figure 19 on page 14).

Note: In some homes, especially older ones, the joists may be slightly thicker than the lumber you can currently buy. If your joists have a different thickness than the lumber you will be using for the headers, you will need to mark the joists back from the edge of your location a distance of two times the header thickness instead of the joist thickness.

STEP 5. Saw through the joist(s) being careful not to cut through the ceiling and making sure the cut ends of the joist(s) are flat and vertical.

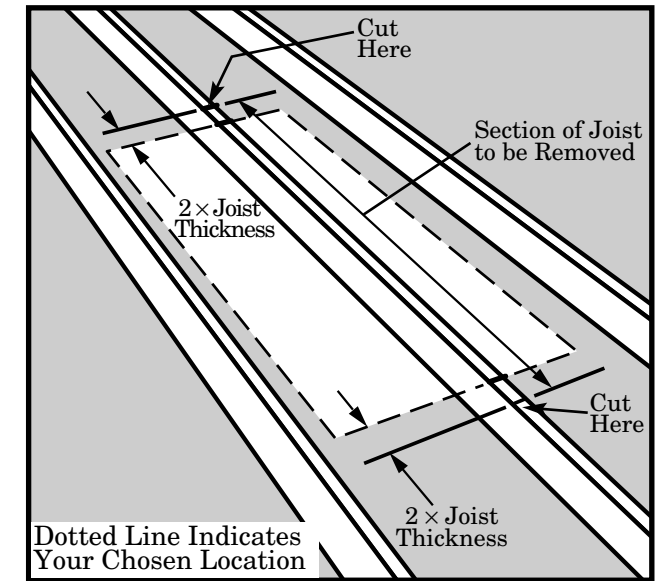

Figure 13

Section 8 FRAMING THE ROUGH OPENING

Before Proceeding: You should have a space between the joists at least as large as the rough opening shown on the box. Any cut joists must be attached to uncut joists.

Goal: To create a four-sided frame the size of the rough opening using joist-sized lumber. This frame will be made of single or double thickness headers and stringers depending upon the particular installation. The frame is necessary to support the access ladder and to reinforce the roof and ceiling structure.

WARNING: For your safety, watch out for overhead hazards. Do not stand or sit on the ceiling or insulation covering the ceiling — the ceiling is not made to support your weight. You can fall through the ceiling even though it looks solid! Only the joists can support weight. To avoid falling through the ceiling, you may want to make a working platform by laying boards across the joist.

Watch out for sharp nails sticking through the roof.

Installing Headers

If no joists have been cut, go to “Single Headers” below.

If any joists have been cut, go to “Double Headers” on page 14.

Single Headers

STEP 1. Measure the header length “H” between the joists as shown in Figure 14.

STEP 2. Cut 2 headers this length. Use joist-sized lumber.

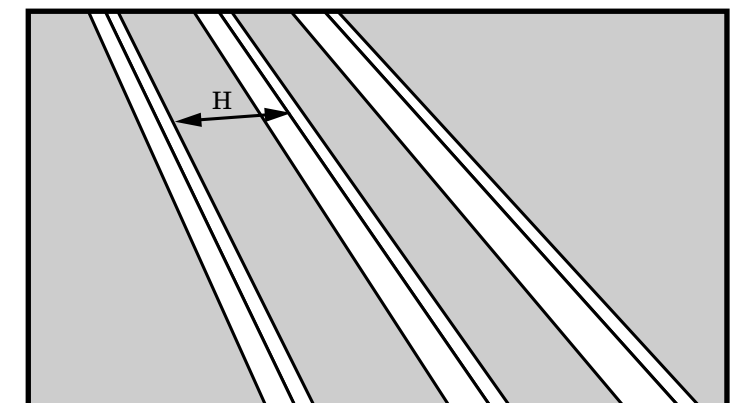

Figure 14

FRAMING THE ROUGH OPENING

STEP 3. Place one of these headers at one end of your chosen location (Figure 15). The header must fit snugly between the joists. Hammer it into position if necessary; if it is more than 1/16 inch too long, trim it. If it is more than 1/16 inch too short, cut another piece.

STEP 4. Square the header to one joist and drive 3 nails (16d) through the joist and into the header. Check for squareness and drive 3 nails (16d) through the other joist and into the header (Figure 15).

STEP 5. Position the second header “E” inches (see Table 3) from first one and repeat Step 4 (Figure 16).

STEP 6. The frame for the rough opening requires four sides. The headers make up two of those sides. If your ceiling joists are spaced so that they make up the other two sides of the rough opening, check the opening for squareness by measuring across the diagonals. The measurements should be within 1/8" to be considered square (Figure 16).

When the frame is square, go on to Section 9. “INSTALLING TEMPORARY SUPPORT BOARDS” on page 16.

If your ceiling joists do not make up the other two sides of the rough opening, you need to install one or two additional pieces of lumber to frame the other side(s) of the rough opening, go to “Installing Stringers” on page 15.

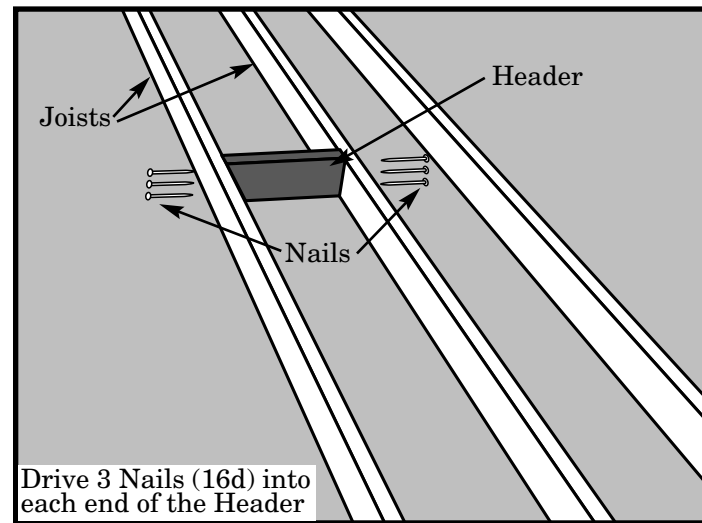

Figure 15

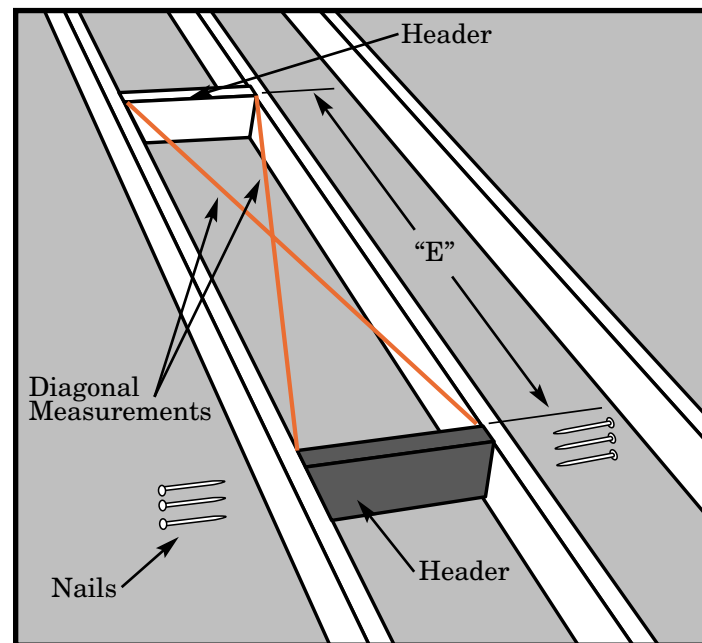

Figure 16

Model Number	“E” Inches
A2208 A2210 A2508 A2510	54"
A2512	66"

Table 3. Distance Between Headers

FRAMING THE ROUGH OPENING

Double Headers

STEP 1. Measure the header length “H” between the uncut joists as shown in Figure 17.

STEP 2. Cut 4 headers this length. Use joist-sized lumber.

STEP 3. Place one of these headers against the end of the cut joist(s) as shown in Figure 18. It must fit snugly between the uncut joists. Hammer it into position if necessary; if it is more than 1/16 inch too long, trim it. If it is more than 1/16 inch too short, cut another piece.

STEP 4. Square the header to the uncut joist and nail the header to the end of the cut joist(s) with 3 nails (16d) as shown in Figure 18.

STEP 5. Check header for squareness then drive 3 nails (16d) through each joist into each end of the header as shown in Figure 18.

STEP 6. Place a second header against the first header and nail it to the first header with 3 nails (16d) between each joist as shown in Figure 19.

STEP 7. Drive 3 nails (16d) through the joists into each end of the second header as shown in Figure 19.

STEP 8. Repeat steps 3-7 to install headers at the opposite end of the opening.

STEP 9. To frame the other side(s) of the rough opening, go to “Installing Stringers” on the next page.

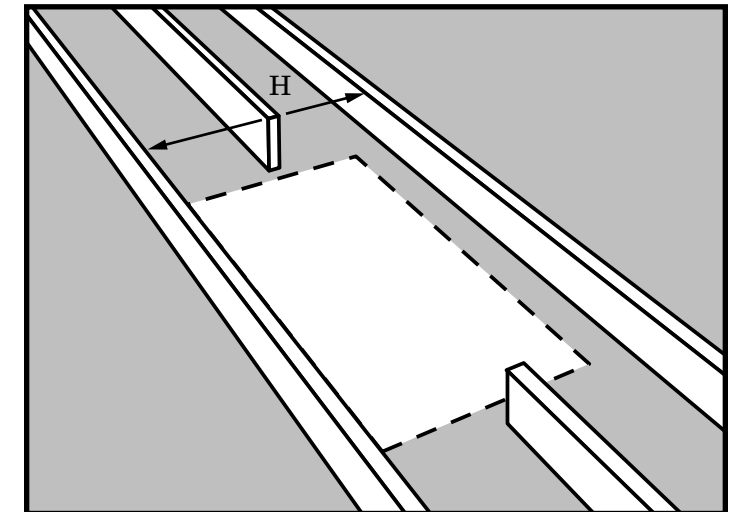

Figure 17

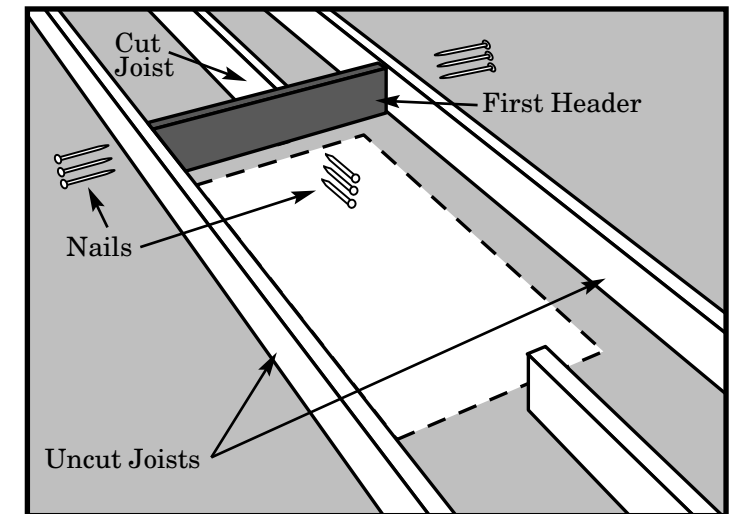

Figure 18

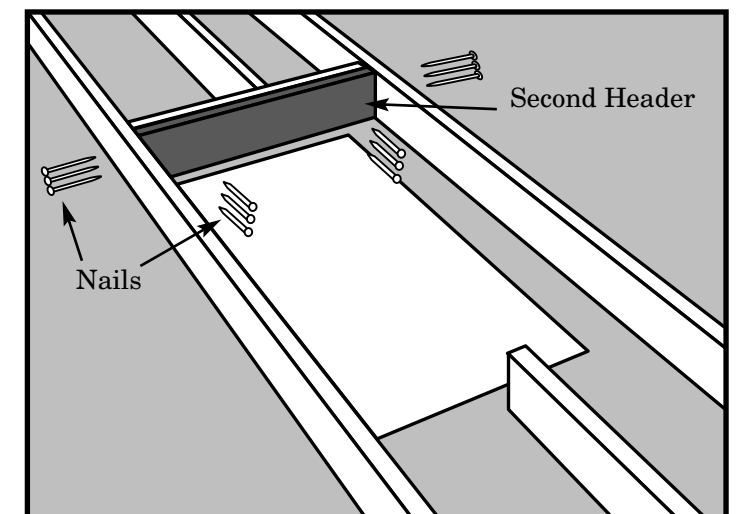

Figure 19

Section 8 (Continued)

FRAMING THE ROUGH OPENING

Installing Stringers

- STEP 1.** Measure the stringer length “S” between the headers (Figure 20).
- STEP 2.** Cut a stringer to this length. Use joist-sized lumber.
- STEP 3.** If the ceiling joist does not provide one side of the frame, then cut a second stringer the same length as the first one. Note that only one stringer is needed in Figure 20 because the ceiling joist provides one side of the frame.
- STEP 4.** Position the stringer(s) along the unframed side(s) of your location (Figure 21). Check that the inside dimensions of the frame are the same as the rough opening shown on the box or in Table 2 on page 9.
- STEP 5.** To attach the stringer(s) to the headers, use nails that are long enough to go through both headers and into the stringer at least one inch. In most cases, a 4 inch nail (20d) will be long enough. Square the stringer(s) to the headers at one end and drive 3 nails through the headers and into the stringer. Check for squareness then nail the other end. Check the rough opening for squareness by measuring across the diagonals. The two measurements should be within 1/8" to be considered square (Figure 21).

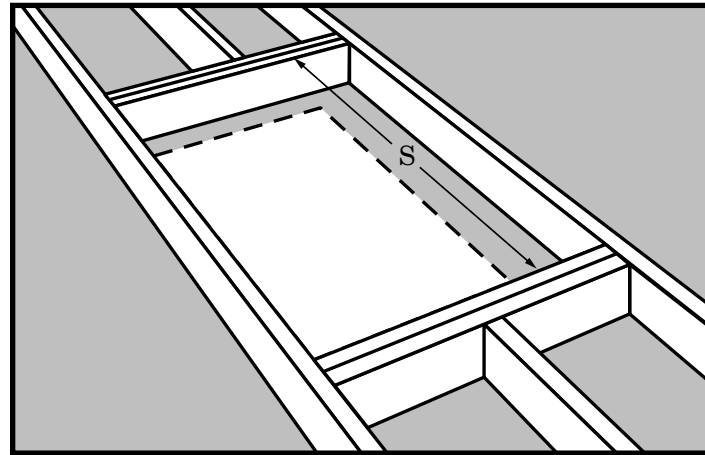

Figure 20

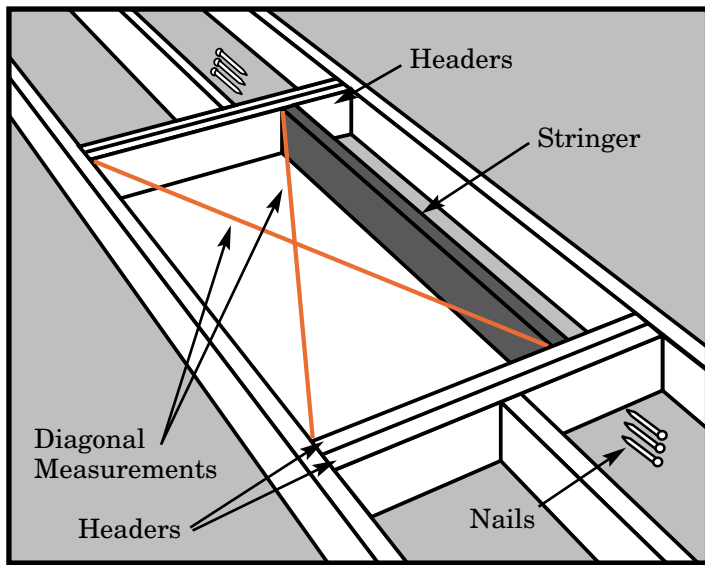

Figure 21

Section 9

INSTALLING TEMPORARY SUPPORT BOARDS

Before Proceeding: You must have a frame of joist-sized lumber the size of the rough opening shown on the box.

Goal: To install temporary support boards at both ends of the frame to provide ledges large enough to support the access ladder while still leaving room to open the access ladder.

- STEP 1.** Using four nails, attach a 1" x 4" x 36" board (temporary support board) at the end of the rough opening where the hinged end of the access ladder will be. This temporary support board must form a 3/8" ledge across the rough opening (Figure 22) on the next page.

Note: Double-headed nails are recommended as they are easily removed when the temporary support boards are no longer needed.

Section 9 (Continued)

INSTALLING TEMPORARY SUPPORT BOARDS

- STEP 2.** Using four nails, attach the second temporary support board to the other end of the rough opening so that the temporary support boards are “E” Inches (see Table 4) apart (Figure 22).

WARNING: Make sure that the temporary support boards are “E” Inches (see Table 4) apart on both sides of the opening. The access ladder is likely to fall from the ceiling if the temporary support boards are not properly spaced.

Model Number	“E” Inches
A2208, A2210 A2508, A2510	52½"
A2512	64½"

Table 4. Temporary Support Boards

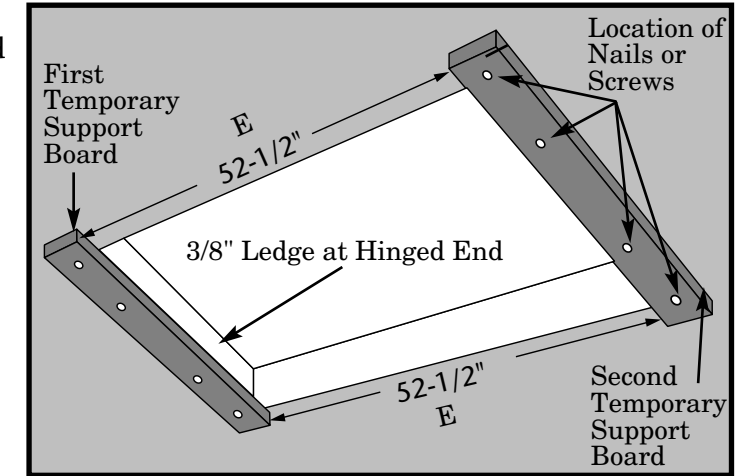

Figure 22 View From Below

Section 10

POSITIONING THE ACCESS LADDER

Before Proceeding: You must have temporary support boards at both ends of the frame as shown in Figure 22.

Goal: To position the access ladder on the temporary support boards in the right direction for use.

- STEP 1.** Assemble push/pull down rod and hook assembly by following the supplemental installation instructions.
- STEP 2.** One person must go into the overhead space while the other person stays below.
- CAUTION:** The access ladder cannot be used to climb into or out of the overhead space until it is permanently nailed to the frame you built and the access ladder legs have been properly trimmed. This means that (in some installations) the person in the overhead space must remain there until the installation is complete.
- STEP 3.** Make sure that people are kept far enough away from the work area that they will not be hit if the access ladder is accidentally dropped while being lifted onto the temporary support boards.
- STEP 4.** Carefully lift the access ladder onto the temporary support boards making sure that the hinged end is in the right place.
- STEP 5.** After predrilling with 1/8" drill bit, nail the hinged end of the frame to the header by driving two 16d nails through the hole in each metal bracket on the headboard (location A at Figure 22).
- STEP 6.** Open the access ladder door by slowly pulling the rod straight down.
- Pulling the rod at angles other than straight down may shift the access ladder off the temporary support boards and cause it to fall.
- Do not push the access ladder open from within the overhead space. The spring tension changes suddenly—you are likely to lose your balance and fall.
- Do not try to force the door open or adjust the temporary support boards while the access ladder is on them. If the access ladder door is blocked by the temporary support boards, remove the access ladder and adjust the temporary support boards as needed.

WARNING: Do not unfold the access ladder legs at this time. The access ladder is not yet safe to use. Do not stand on the access ladder or leave it unattended until it is permanently nailed to the frame AND the legs are properly trimmed. Using the access ladder before the legs are properly trimmed will damage the access ladder and may cause it to break unexpectedly resulting in serious injury.

Section 11

SHIMMING, SQUARING AND NAILING THE ACCESS LADDER IN PLACE

Before Proceeding: The access ladder should be positioned on the temporary support boards in the right direction for use. The access ladder door should be open, but the legs should not be extended.

Goal: To shim the access ladder squarely into the frame you built and then nail it at the proper locations.

WARNING: Do not unfold the access ladder legs at this time. The access ladder is not yet safe to use. Do not stand on the access ladder or leave it unattended until it is permanently nailed to the frame AND the legs are trimmed AND the feet are properly adjusted. Using the access ladder before the legs and feet are properly adjusted will damage the access ladder and may cause it to break unexpectedly resulting in serious injury.

STEP 1. Shim the access ladder with wood blocks or tapered shim stock at the locations shown in Figure 23 until the access ladder fits squarely in the frame you built. Tapered shims should be inserted from above and below (where possible).

NOTICE: Failure to properly square the ladder frame may result in premature damage to the closing mechanism.

Check the frame for squareness by measuring across the diagonals (See Fig. 24). The two measurements should be within 1/8" to be considered square.

STEP 2. Pre drill all nail locations shown with arrows in Figure 24 using a 1/8" drill bit. Do not drill into the joists or headers. Nail the access ladder to the frame following these instructions.

- a. Drive ten 16d nails, checking squareness and re-shimming as necessary, as shown in Figure 24. Nails at locations marked "B" must go through the hole in each of the metal brackets. Push the ladder up from below until the hole in the bracket is uncovered, then drive the nail through the hole. Locations marked "C" indicate that a nail should be driven through each wooden "stop block".
- b. Be careful not to hit the springs with the hammer.

STEP 3. Trim the portion of the shims that stick out above and below the frame. Shims sticking out above the frame are a tripping hazard and must be removed.

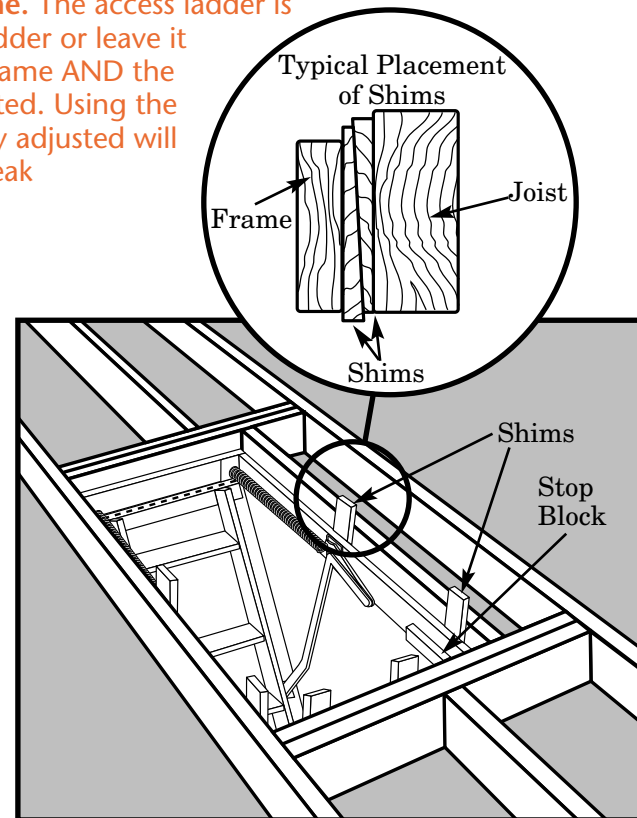

Figure 23

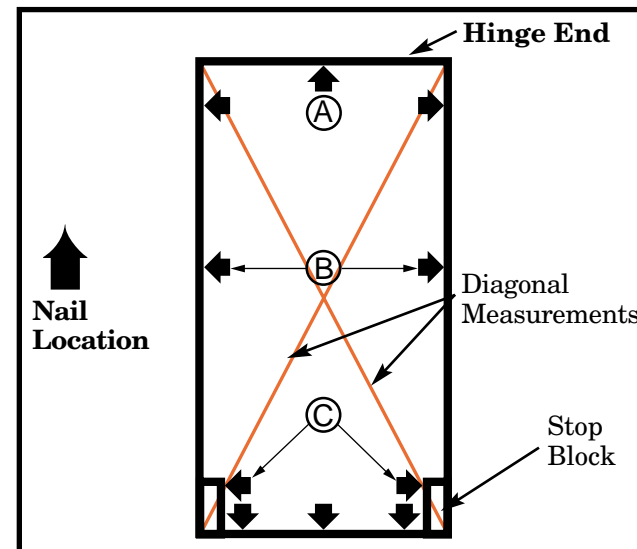

Figure 24

Section 12

TRIMMING THE ACCESS LADDER LEGS

Before Proceeding: You should have the access ladder shimmed and nailed at the proper locations.

Goal: To trim the access ladder legs and adjust the feet so that they fit flush with the floor and there are no gaps between the hinged sections of the access ladder when it is fully extended. It is extremely important that you do not trim the legs too short!

WARNING: Do not unfold the access ladder legs at this time. The access ladder is not yet safe to use. Do not stand on the access ladder or leave it unattended until it is permanently nailed to the frame AND the legs are trimmed AND the feet are properly adjusted. Using the access ladder before the legs and feet are properly adjusted will damage the access ladder and may cause it to break unexpectedly resulting in serious injury.

STEP 1. Pull the access ladder door down until it locks open.

STEP 2. Fold the bottom section of the access ladder under the middle section. (Figure 25)

STEP 3. With a straight edge, measure distance "E" as shown in Figure 25 and record the measurements in the spaces below. Be sure to measure distance "E" from the top edge of the rails. These distances must be accurately measured to avoid trimming the legs too short.

NOTE: Measure "E" on both sides of the access ladder — the ceiling-to-floor height may not be the same for both sides of the ladder!

"E" Left Rail _____ "E" Right Rail _____
 — 3 in. — 3 in.

"F" Left = _____ "F" Right = _____

STEP 4. Dimension "F" is found by subtracting 3 inches from the "E" measurement. Measure down from the top of the lower section and mark the rail at the "F" dimension on each rail. Using a square, draw a trim line across each rail. These trim lines must be drawn accurately to avoid trimming the legs too short.

STEP 5. If either trim line passes through a step, that step will have to be removed. Remove the step by drilling out the rivets that connect the step to the rail. Using a 13/64" diameter bit, through the center of the rivet heads (located on the outside of the rail) until the rivet head falls off. If the rivet head does not fall off, gently tap with a chisel and hammer keeping the chisel

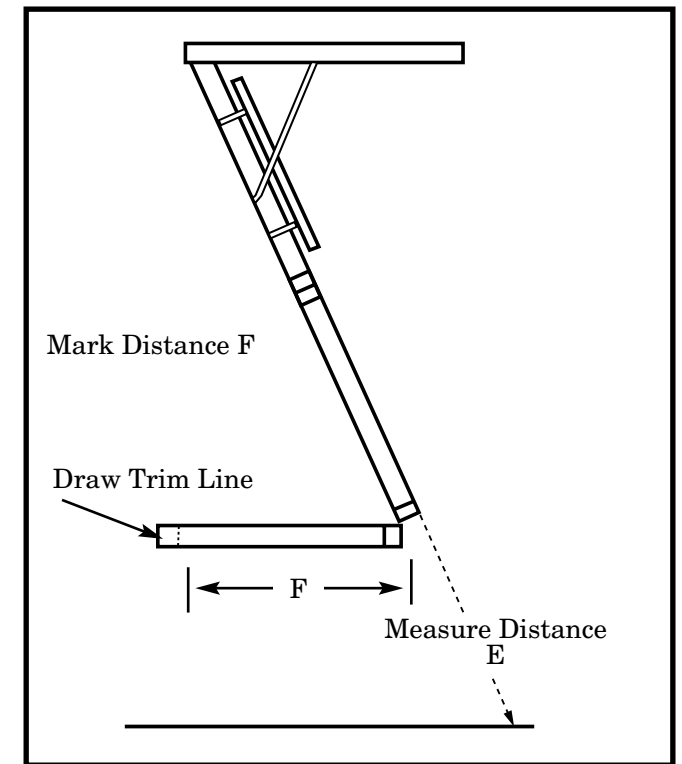

Figure 25

parallel with the rail surface. Be careful not to drill into the access ladder rail. Once all six rivets are removed, pull the step out between the rails.

Go to the next page to finish trimming and adjusting the access ladder legs.