

ATTIC STAIRWAY COMPONENT LISTING

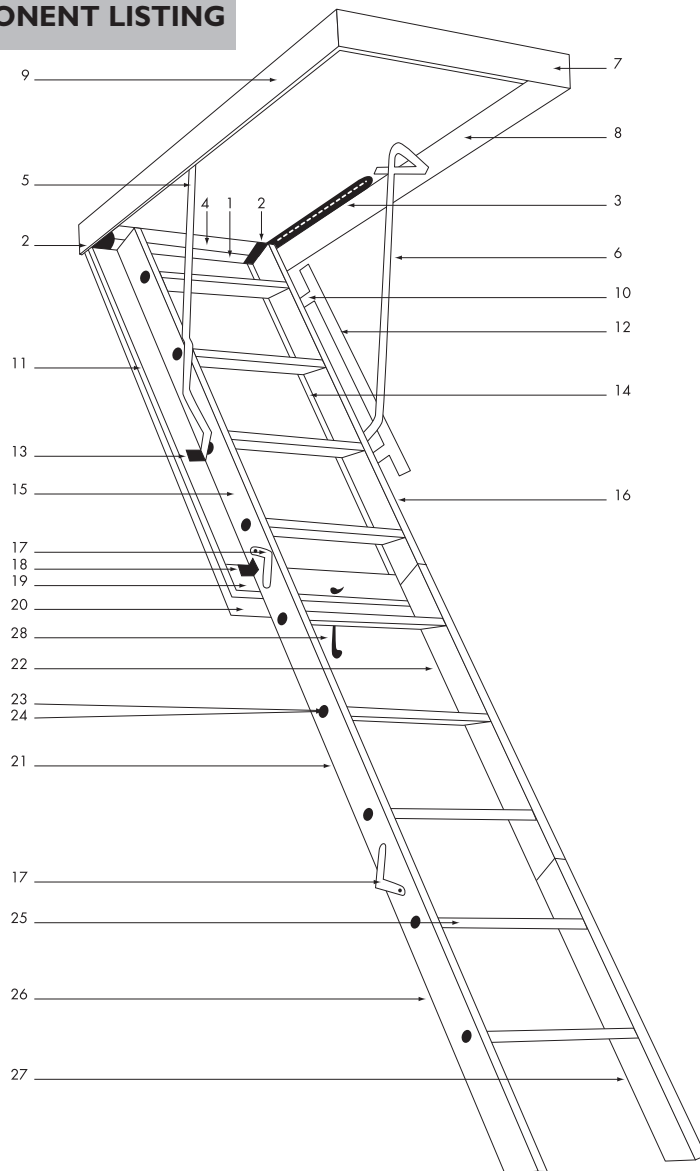

- 1 – Full-width piano hinge
- 2 – Piano hinge bracket
- 3 – Spring (2)
- 4 – Header board
- 5 – Left power arm
- 6 – Right power arm
- 7 – Box end
- 8 – Right box side
- 9 – Left box side
- 10 – Handrail bracket (2)
- 11 – Left door runner
- 12 – Handrail
- 13 – Power arm mounting bracket (2)
- 14 – Right door runner
- 15 – Left top stile
- 16 – Right top stile
- 17 – Side hinge (4)
- 18 – Frame bracket
- 19 – Door frame end
- 20 – Door panel
- 21 – Left center stile
- 22 – Right center stile
- 23 – Ladder rods
- 24 – Ladder rod washers
- 25 – Steps
- 26 – Left lower stile
- 27 – Right lower stile
- 28 – Pull cord and tassel

SPECIAL NOTE TO USER:

Always face the stairway when going up or down; and use the handrail.

CAUTION:

The bottom section of each leg of the stairway must always be trimmed so that its ends rest flush with the floor and all sections of the legs are perfectly aligned.

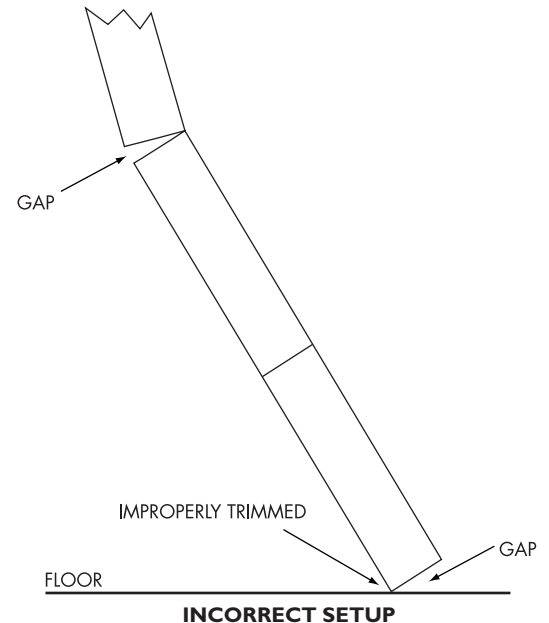
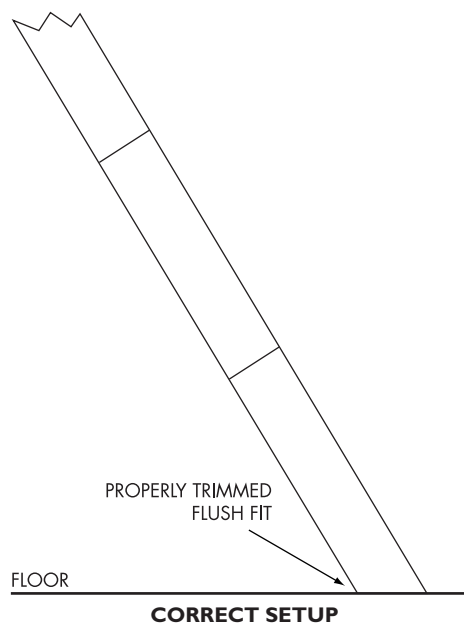

INSTRUCCIONES DE INSTALACION

**ANTES DE COMENZAR LEA TODAS LAS INSTRUCCIONES.
SE NECESITAN DOS PERSONAS PARA QUE LA INSTALACION SEA CORRECTA Y MAS FACIL.**

ERRAMIENTAS Y MATERIALES REQUERIDOS:

Martillo, escalera, destornillador para tornillos cruciformes, destornillador para tornillos de ranura, escuadra, cinta métrica, serrucho, tornillos Tirafondo de 3 pulgs., clavos 16d, clavos 8d, listones de 1 x 4 pulgs. para sostén temporal (2 piezas de 32 pulgs. de largo aproximadamente), puntales con las mismas dimensiones que las viguetas y madera contrachapada de 1/4 o 3/8 de pulg. para calzas.

INSPECCION DEL PRODUCTO

¡NO DESARME LA ESCALERA! VERIFIQUE QUE TODAS LAS TUERCAS, PERNOS Y TORNILLOS ESTÉN BIEN APRETADOS. Quite la cuerda y la borla de la escalera y hágala pasar por el orificio en la puerta de madera contrachapada.

UBICACION DE LA ESCALERA

A. Antes de comenzar la instalación, mida y verifique la altura del techo (cielo raso) (la distancia entre el piso terminado y el techo terminado).

B. Deje un área suficiente para el espacio para el descanso seguro de la parte inferior de la escalera. Verifique que haya suficiente espacio libre para la oscilación de la escalera, cuando ésta sea desdoblada a su longitud total (vea en la FIGURA 1 “espacio para descanso” y “proyección”; iguale las alturas del techo mostradas en la caja de empaque con la misma altura del techo en la TABLA A, para determinar los requerimientos correctos para los espacios para descanso y proyección).

PARA HACER LA ABERTURA

A. Corte la abertura preliminar en el material del techo tal como se muestra en la TABLA A.

B. Enmarque la abertura preliminar al tamaño mostrado en la caja de empaque.

C. Si es necesario cortar viguetas del techo, **CERCIÓRESE** de asegurar los miembros cortados a otras viguetas con un puntal de travesaño o larguero de las mismas dimensiones (vea las FIGURAS 2 y 3).

INSTALACION DE LOS SOSTENES TEMPORALES

Es necesario sostener la escalera temporalmente dentro de la abertura preliminar preparada, utilizando los listones de 1 x 4 pulgadas que se extienden de borde a borde a cada extremo de la abertura preliminar. Los listones forman un resalto para sostener la escalera antes que sea fijada permanentemente. Es importante tener cuidado al poner en posición los listones. Clave los listones por debajo del techo a los travesaños tan cerca de los bordes de la abertura preliminar como sea posible, para máxima resistencia. Los listones deben sobresalir solamente de 3/8 a 5/8 de pulg. dentro de la abertura preliminar. El panel de madera contrachapada debe quedar libre para poder oscilar y abrirse (vea la FIGURA 4).

COLOCACION DE LA ESCALERA DENTRO DE LA ABERTURA

A. La escalera cerrada debe ser ahora levantada e introducida dentro de la abertura preliminar y colocada en posición sobre los resaltos formados por los listones. Trabajando por encima con un ayudante por debajo, levante la escalera a través de la abertura preliminar en ángulo para que pueda pasar por los listones. Coloque la escalera en posición dentro de la abertura preliminar. **EN ESTE MOMENTO NO SE PARE SOBRE LA ESCALERA NI LA ABRA.**

Asegúrese de que tiene un ayudante debajo de la escalera, para que pueda abrirla y para terminar la instalación.

B. Utilizando varios clavos 8d, fije la escalera temporalmente dentro de la abertura clavando en ángulo los lados del hueco a las viguetas adyacentes. No clave estos clavos completamente para que se pueda sacarlos después que se ha completado el clavado permanente.

C. Una vez que se ha completado el clavado temporal, instruya a su ayudante que está debajo, que quite los listones temporales y que abra con cuidado el panel de la puerta de la escalera, y que baje las secciones de la escalera de forma que el área para el clavado permanente quede expuesto. **NO SE PARE SOBRE LA ESCALERA EN ESTE MOMENTO.**

MONTAJE PERMANENTE DE LA ESCALERA

A. Verifique que la escalera está en escuadra y a nivel dentro de la abertura preliminar. Si el marco de la escalera se ha combeado mientras estaba almacenado, se lo puede enderezar con clavos y bloques de madera. El combeado es normal debido a que las piezas de madera están sujetas a la fuerte tensión del resorte durante un tiempo, antes de la compra e instalación (vea la FIGURA 5).

B. Con los clavos 16d o con los tornillos tirafondos de 3 pulgadas, clave los lados (jambas) del marco de la escalera al marco de la abertura preliminar. Se proveen orificios ya hechos en las placas pivote y ménsulas de bisagra de piano. También clave las tablas de los extremos dentro de los dinteles de la abertura preliminar. Complete la instalación permanente clavando suficientes clavos 16d para asegurar el marco de la escalera a los cuatro lados de la abertura preliminar. Saque los clavos 8d y los listones usados para sostén temporal.

AJUSTE DE LA ESCALERA A LA ALTURA DEL TECHO

Tire de la escalera hacia abajo, aplicando presión para que los brazos metálicos queden totalmente extendidos. Abra las secciones de la escalera, doblando la sección inferior debajo de la sección del medio. Las secciones superior y del medio deben formar una línea recta. Alineando su regla al mismo plano de las dos secciones superiores, mida la distancia desde la parte inferior de la sección del medio hasta el piso, adelante y atrás (vea la FIGURA 7). Marque las distancias obtenidas de los lados de adelante y de atrás de los extremos de la sección inferior y rebaje las secciones inferiores a la longitud y ángulos correctos cortándolas transversalmente. Con la sección inferior cortada a la longitud y ángulo correctos, las articulaciones estarán apretadas en cada sección cuando haya peso sobre la escalera.

ADVERTENCIA: La sección inferior debe apoyarse al ras con el piso. Si no es cortada correctamente, se podrían aplicar esfuerzos indebidos a las piezas componentes de la escalera, y causar lesiones graves (vea las FIGURAS 8 y 9).

AJUSTE DE LA TENSION DE LOS RESORTES

Su escalera está equipada con un medio único y fácil para ajustar la tensión de cada uno de los dos resortes. Con la escalera cerrada, use una llave ajustable de 7/16 de pulgada y apriete (girando hacia la derecha) las tuercas de seguridad de los ganchos J que fijan los resortes al panel de la puerta. Apriete cada resorte en forma alternada, para elevar el panel de la puerta en forma pareja para que quede al ras con el techo.

MONTAJE DE CONTRAMARCOS EN LA ABERTURA DE LA ESCALERA

A. Escoja una moldura que combine con las molduras en su casa: una moldura de 5/8 o 2 1/4 pulgadas Clam Shell (almeja) es una selección popular.

B. Deje un espacio de 3/8 de pulgada entre el panel de la puerta y la moldura en el lado de las bisagras de la escalera, para proveer el espacio libre cuando se abre la escalera.

C. El resto de la moldura puede ser colocado aproximadamente a 1/8 de pulgada de los bordes del panel de la puerta de madera contrachapada.

SUGERIMOS PINTAR LOS TRAVESAÑOS O LARGUEROS

Ahí está ... el trabajo está terminado!

PRECAUCION: CONSEJOS DE SEGURIDAD

- Se requiere mantenimiento periódico. Verifique todas las tuercas, pernos y tornillos para asegurarse de que están bien apretados.
- Antes de cada uso, cerciórese de que la escalera esté alineada correctamente.
- Verifique periódicamente los pernos “J” y los resortes.
- Los resortes se encuentran bajo tensión. Tenga mucho cuidado cuando los ajusta o revisa.



WERNER CO., 93 WERNER ROAD, GREENVILLE, PA 16125-9499
Phone: (724) 588-8600
www.wernerladder.com



SpaceMaster®

URNS EMPTY SPACE INTO STORAGE SPACE!®

THIS STAIRWAY IS DESIGNED FOR RESIDENTIAL USE ONLY. INSTALLATION INSTRUCTIONS

**READ THE INSTRUCTIONS COMPLETELY BEFORE STARTING.
TWO PEOPLE ARE REQUIRED FOR PROPER AND EASIER INSTALLATION.**

TOOLS AND MATERIALS NEEDED:

Hammer, ladder, Phillips-head screwdriver, slot-head screwdriver, square, tape measure, saw, 3" lag screws, 16d nails, 8d nails, 1" x 4" temporary support slats (2 pieces approx. 32" long), braces with same dimensions as joists; and 1/4" or 3/8" plywood for shims

BEFORE INSTALLATION:

Verify that this product and its installation meet all applicable building codes. Check stair carefully for shipping damage. Please mark the model name and size of the stair you purchased on the Installation Instructions for future reference.

Model #	Rough Opening	Ceiling Height Range	Landing Space (1)	Projection (2)
W Series (Load Rating: 250 lbs.)				
W2208	22-1/2" x 54"	84" – 105"	64"	65"
W2210	22-1/2" x 54"	105" – 120"	67"	73"
W2508	25-1/2" x 54"	84" – 105"	64"	65"
W2510	25-1/2" x 54"	105" – 120"	67"	73"
WH Series (Load Rating: 350 lbs.)				
WH2208	22-1/2" x 54"	84" – 105"	64"	68"
WH2210	22-1/2" x 54"	105" – 120"	72"	76"
WH2508	25-1/2" x 54"	84" – 105"	64"	68"
WH2510	25-1/2" x 54"	105" – 120"	72"	76"
WH3008	30" x 54"	84" – 105"	64"	68"
WH3010	30" x 54"	105" – 120"	72"	76"
A Series (Load Rating: 300 lbs.)				
A2208	22-1/2" x 54"	84" – 105"	68"	70"
A2210	22-1/2" x 54"	105" – 120"	73"	78"
A2508	25-1/2" x 54"	84" – 105"	68"	70"
A2510	25-1/2" x 54"	105" – 120"	73"	78"
A2512	25-1/2" x 64"	137" – 144"	84"	87"

TABLE A

Keep this instruction brochure with the installed stair.

You should have experience with squaring, leveling, sawing, and aligning structural supports before attempting to install this unit. If you do not have the skills to install a window frame or door unit, please hire a professional to install this stairway. Improper installation could result in stairway collapse and possible bodily injury.

INSPECTION OF MERCHANDISE

DO NOT DISASSEMBLE STAIRWAY! MAKE SURE ALL NUTS, BOLTS AND SCREWS ARE SECURELY FASTENED.

Remove cord and tassel from stairway and place through hole in plywood door.

LOCATING THE STAIRWAY

A. Measure and verify ceiling height (the distance from the finished floor to the finished ceiling) prior to beginning installation.

B. Allow sufficient area for a safe landing space at the bottom of the stairway. Be sure there is enough clearance for the swing of the stair as it is being unfolded to its full length (see FIGURE 1 for "landing space" and "projection"; match the ceiling heights shown on the packing carton with the same ceiling height in TABLE A to determine proper landing space and projection requirements).

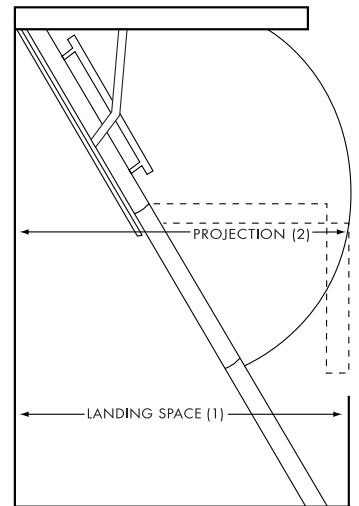

FIGURE 1 - WOOD STAIRWAYS

MAKING THE OPENING

A. Cut the rough opening through the ceiling material as shown in TABLE A.

B. Frame the rough opening to the size shown on carton.

C. If it is necessary to cut ceiling joists, **BE SURE** to tie the cut members to other joists with a header or stringer brace of the same dimensions (see FIGURES 2 and 3).

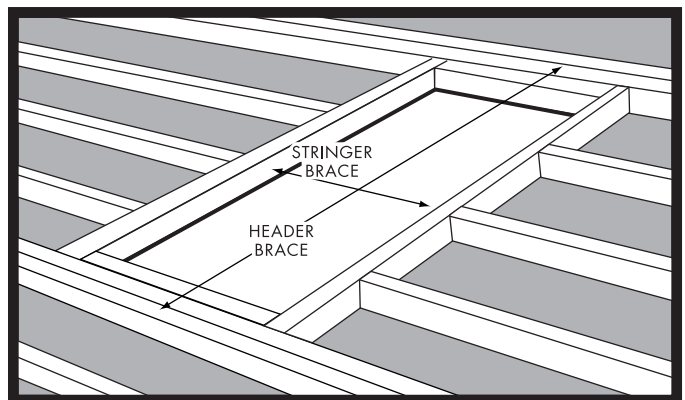
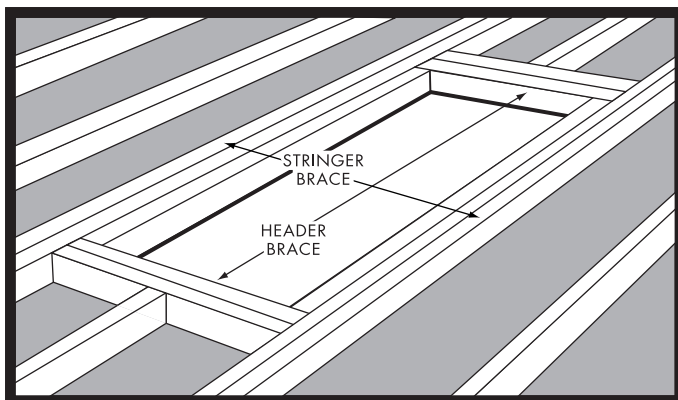

FIGURE 2 - NOTE: KEEP THE CORNERS SQUARE TO SIMPLIFY INSTALLATION - FIGURE 3

INSTALLING TEMPORARY SUPPORTS

It is necessary to temporarily support the stairway in the prepared rough opening by using 1" x 4" slats that extend from edge to edge across each end of the rough opening. The slats form a ledge to support the stairway before it is permanently secured. Care is important in positioning the slats. Nail the slats below the ceiling onto the headers as close to the edges of the rough openings as practical for maximum strength. They should extend only 3/8" - 5/8" into the rough opening. The plywood panel must be free to swing open (see FIGURE 4).

The slats must be nailed securely enough to temporarily support the weight of the stairway when it is placed in the rough opening.

CAUTION: DO NOT PLACE ANY WEIGHT ON THE STAIRWAY UNTIL PERMANENT NAILING IS COMPLETED.

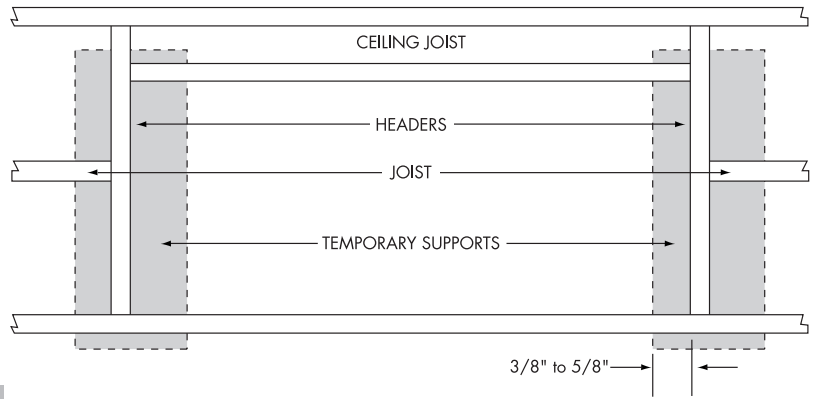

FIGURE 4 - FRAMED OPENING WITH TEMPORARY SUPPORT SLATS READY TO RECEIVE STAIRS

PLACING STAIRWAY INTO OPENING

A. While closed, the stairway should now be raised into the rough opening and positioned on the ledges formed by the slats. Working above with a helper below, raise the stairway through the rough opening at an angle so it will clear the slats. Position the stairway in the rough opening. **DO NOT STAND ON OR OPEN THE STAIRWAY AT THIS TIME.** Make sure you have a helper, below, who can open the stairway to allow completion of the installation.

B. Using at least three evenly spaced 8d nails per side, temporarily affix the stairway in the opening by nailing, at an angle, the well sides to the adjacent joists. Do not drive these nails in all the way so they can be removed later after the permanent nailing is completed.

C. Once the temporary nailing has been completed, have your helper, below, open the stairway door panel and lower the stair sections so that the area for permanent nailing is exposed. **DO NOT STAND ON THE STAIRWAY AT THIS TIME.**

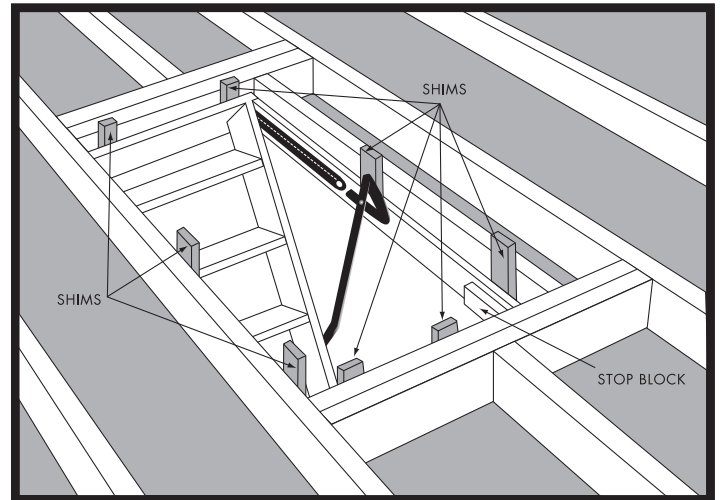
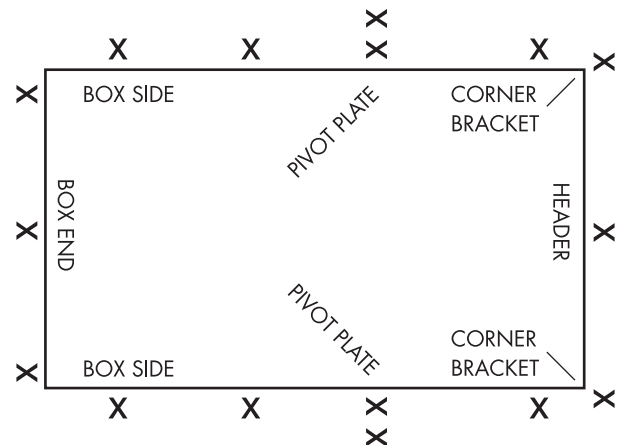

FIGURE 5

PERMANENT MOUNTING OF STAIRWAY

A. Be sure stairway is square and level in the rough opening. If the stair frame has bowed while the stairway was in inventory, nails and blocks of wood used as shims will straighten it. Bowing is normal since wood parts are subjected to strong spring tension for some time before purchase and installation (see FIGURE 5).

B. Nail the sides (jambs) of the stairway frame to the rough opening frame, using 16d nails or 3" lag screws. Holes are provided in the pivot plates and piano hinge brackets. Also nail through the end boards into the rough opening headers. Complete permanent installation by using 16d nails or 3" lag screws to secure stairway frame on all four sides of the rough opening according to the diagram in FIGURE 6. Use *at least* three evenly spaced fasteners on each box end and *at least* five evenly spaced fasteners on each box side. Remove the 8d nails and the slats used for temporary support.



X- INDICATES RECOMMENDED LOCATION OF 16d NAILS OR 3" LAG SCREWS

FIGURE 6

ADJUSTING STAIRWAY TO CEILING HEIGHT

Pull stairway down, applying pressure so that hardware arms are fully extended. Open the stair sections, folding bottom section under the middle section. The top and middle sections should form a straight line. Aligning your ruler on the same plane as the two upper sections, measure the distance from the bottom of the middle section to the floor on the front and back (see FIGURE 7). Mark the distances obtained on the front and back sides of the ends of the bottom section, and trim bottom sections at the proper length and angles by cutting across them. With the bottom section cut to the proper length and angle, joints will be tight at each section with weight on the stairs. NOTE: For aluminum stairways, please refer to the bottom of this page.

WARNING: The bottom section must fit flush with the floor. Failure to cut properly could result in undue stress on the component parts of the stairway, resulting in serious injury (see FIGURES 8 and 9).

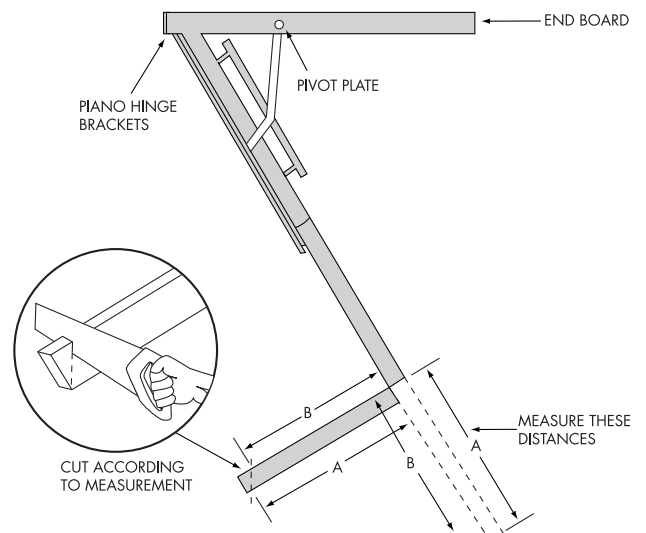

FIGURE 7 - ADJUSTMENT TO CEILING HEIGHTS AND NAIL POSITIONS

ADJUSTING THE SPRING TENSION

Your stairway is equipped with a unique and easy way to adjust the tension on each of the two springs. With the stairway in the closed position, use an adjustable or 7/16" wrench and tighten (turn clockwise) the locknuts on the J-hooks that attach the springs to the door panel. Alternate the tightening of each spring to raise the door panel evenly so it ends up flush with the ceiling.

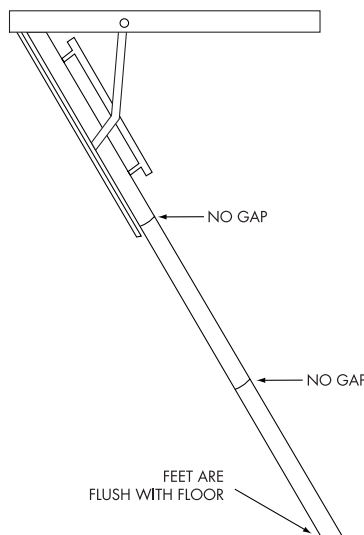

FIGURE 8 - CORRECT SETUP

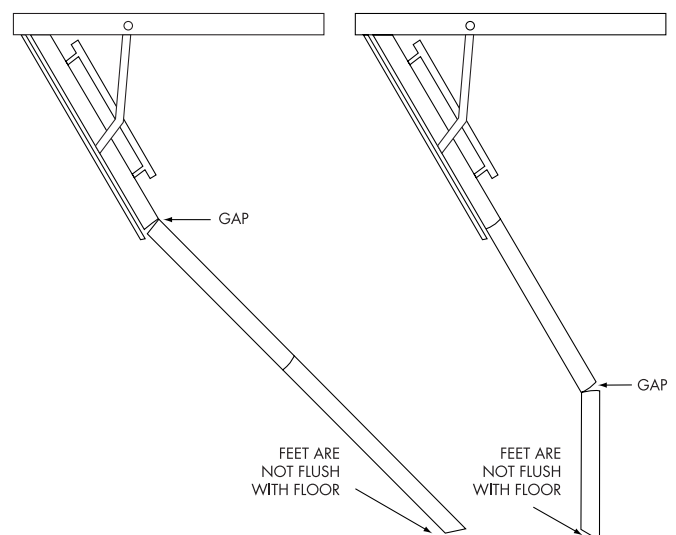

FIGURE 9 - INCORRECT SETUPS

Aluminum stairways come preassembled with adjustable feet. Height adjustments may be made by removing the nuts and bolts on the bottom section and repositioning the feet to the correct height. NOT ALL CEILING HEIGHTS CAN BE ADJUSTED IN THIS MANNER. If your stairway cannot be properly adjusted using the predrilled hole locations, please refer to the INSTRUCTIONS FOR ADJUSTING THE HEIGHT OF ALUMINUM ATTIC STAIRWAYS.

ALUMINUM STAIRWAYS

Model #	Rough Opening	Ceiling Height Range	Landing Space (1)	Projection (2)
A2208	22-1/2" x 54"	84" - 105"	68"	70"
A2210	22-1/2" x 54"	105" - 120"	73"	78"
A2508	25-1/2" x 54"	84" - 105"	68"	70"
A2510	25-1/2" x 54"	105" - 120"	73"	78"
A2512	25-1/2" x 64"	137" - 144"	84"	87"

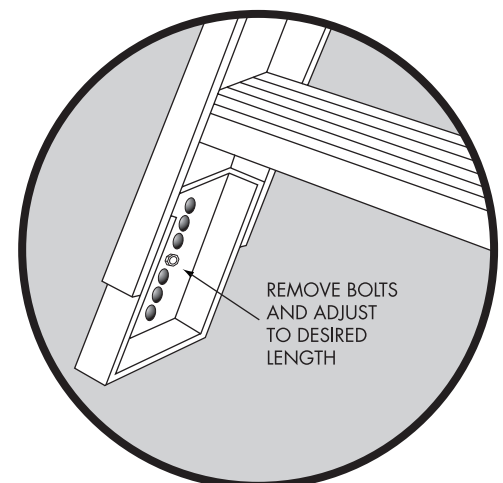

FIGURE 10

TRIMMING THE STAIRWAY OPENING

- A.** Select a molding that blends with the trim in your home: a 5/8" or 2 1/4" Clam Shell molding is a popular choice.
- B.** Leave a 3/8" space between the door panel and the trim at the hinge end of the stairway to provide clearance when the stairway is opened.
- C.** The balance of the trim may be placed approximately 1/8" from the edges of the plywood door panel.

WE SUGGEST PAINTING STRINGERS OR STILES

There ... The Job Is Finished!

CAUTION: SAFETY TIPS

- Regular maintenance is required. Check all nuts, bolts and screws to be sure they are tightened.
- Make certain the stairway is aligned properly before each use.
- Check "J" bolts and springs on a regular basis.
- Springs are under tension. Use extreme caution when adjusting or checking.

INSTRUCTIONS FOR ADJUSTING THE HEIGHT OF ALUMINUM ATTIC STAIRWAYS

Before Proceeding: You should have the stairway shimmed and nailed at the proper locations.

It is now time to trim the stairway legs and adjust the feet so that they fit flush with the floor and there are no gaps between the hinged sections of the stairway when it is fully extended. It is extremely important that you do not trim the legs too short!

WARNING: Do not stand on the stairway at this time or leave it unattended until the stairway is permanently nailed to the frame and the legs trimmed and the feet properly adjusted. Using the stairway before the legs and feet are properly adjusted will damage the stairway and may cause it to break or collapse unexpectedly, resulting in serious injury.

1. Pull the stairway door down until it locks open.
2. Fold the bottom section of the unit under the middle section. (Fig. A)
3. With a straightedge, measure distance "E" as shown in Fig. A and record the measurements in the spaces below. Be sure to measure distance "E" from the top edge of the side rails. These distances must be accurately measured to avoid trimming the legs too short.

NOTE: Measure "E" on both sides of the stairway; the ceiling-to-floor height may not be the same for both sides of the stairway!

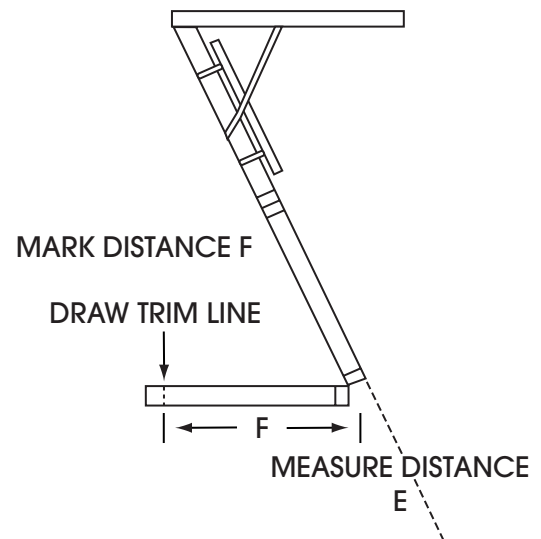

Figure A

